

# 5EAS5

---

**P54C/P55C PCI Mainboard  
User's Guide &  
Technical Reference**



**SOYO™**

---

## About This Guide

This User's Guide is for assisting system manufacturers and end users in setting up and installing the mainboard. Information in this guide has been carefully checked for reliability; however, no guarantee is given as to the correctness of the contents. The information in this document is subject to change without notice.

## Copyright Notice

Copyright 1997, Soyo Computer Inc. All rights reserved. This manual is copyrighted by Soyo Computer Inc. You may not reproduce, transmit, transcribe, store in a retrieval system, or translate into any language, in any form or by any means, electronic, mechanical, magnetic, optical, chemical, manual, or otherwise, any part of this publication without express written permission of Soyo Computer Inc.

## Trademarks

Soyo is a registered trademark of Soyo Computer Inc. All trademarks are the property of their owners.

## Disclaimer

Soyo Computer Inc. makes no representations or warranties regarding the contents of this manual. We reserve the right to revise the manual or make changes in the specifications of the product described with in it at any time without notice and without obligation to notify any person of such revision or change. The information contained in this manual is provided for general use by our customers. Our customers should be aware that the personal computer field is the subject of many patents. Our customers should ensure that they take appropriate action so that their use of our products does not infringe upon any patents. It is the policy of Soyo Computer Inc. to respect the valid patent rights of third parties and not to infringe upon or assist others to infringe upon such rights.

## Restricted Rights Legend

Use, duplication, or disclosure by the Government is subject to restrictions set forth in subparagraph (c)(1)(ii) of the Rights in Technical Data and Computer Software clause at 252.277-7013.

## Product Rights

Product mentioned in this manual are mentioned for identification purpose only. Product names appearing in this manual may or may not be registered trademarks or copyrights of their respective companies.

If you need any further information, please come to our home page on internet. The address is "<http://www.soyo.com.tw>".

**Edtltion : September 1997**  
**Version 1.2**  
**5EAS5 SERIAL**

**100%** POST CONSUMER  
RECYCLED PAPER

# Table of Contents

<b>Chapter 1: Introduction.....</b>	<b>1</b>
Key Features.....	1
Unpacking the Mainboard.....	2
Electrostatic Discharge Precautions.....	2
Mainboard Layout W/ Default Settings.....	3
Remarks on the Cyrix and IBM P200 CPUs.....	5
Voltage Setting List.....	5
<b>Chapter 2: Hardware Setup.....</b>	<b>6</b>
Jumpers.....	6
JP5: CMOS Clear Jumper.....	6
J25: EMI Ground Pin.....	6
JP16: PCI Bus Asynchronous/Synchronous Jumper.....	7
CPU Type Configuration.....	8
Step 1: Frequency Setting.....	8
P54C/P55C-75/90/100 CPU Settings (1.5 x clock).....	8
P54C/P55C-100/120/133 CPU Settings (2.0 x clock)....	9
P54C/P55C-150/166 CPU Settings (2.5 x clock).....	10
P54C/P55C-180/200 CPU Settings (3.0 x clock).....	10
3.5x clock CPU Settings (233 MHz CPUs).....	11
4.0x clock CPU Settings (266 MHz CPUs).....	11
Step 2: CPU Single/Dual Voltage Setting.....	12
Single Voltage CPU Setting.....	12
Dual Voltage CPU Setting.....	13
Memory Configuration.....	13
Memory Configuration Table.....	14
RAM Bank Installation Notice.....	14
Cache Configuration.....	14
Cache Size and RAM Locations.....	14
Multi I/O Port Addresses.....	15
Connectors.....	15
COM1, COM2-COM1/COM2 Connectors.....	15
FDC Connector.....	15
J19-Hardware Reset Control.....	15
J24-HDD LED Connectors.....	15
CN5-IR Connector.....	16
CN2-Keyboard Connector.....	16

J17-Keylock & Power LED Connector.....	16
IDE1/IDE2 - Onboard Primary/Secondary IDE Connectors.	16
CN1-PS/2 Mouse Connector.....	16
PRT-Parallel Port Connector.....	16
AT Power Conn. - AT power supply connector.....	16
J23: Sleep Switch Connector Enable/Disable.....	17
CN3-Universal Serial Bus Connectors.....	17
J18 speaker.....	17

**Chapter 3: BIOS setup.....18**

Standard CMOS Setup.....	19
BIOS Features Setup.....	21
Chipset Features Setup.....	24
Power Management Setup.....	26
PNP/PCI Configuration Setup.....	29
Load Setup Defaults.....	31
Load BIOS Defaults.....	31
Integrated Peripherals.....	32
Supervisor Password.....	34
USER Password.....	35
IDE HDD Auto Detection.....	36

**Appendix.....37**

Appendix A: Jumper for Cyrix/IBM CPU(J100).....	37
Appendix B : Quick Installation Guide.....	38

# 1 Introduction

The EQ82C661X PCI mainboard is a high-performance **AT form-factor** system board that supports P54C/P55C family CPUs. You can order 512K of external cache memory on the mainboard. The mainboard is fully compatible with industry standards, and adds many technical enhancements.

## Key Features

---

- CPU
  - Supports P54C/P55C family CPUs running at 90~200 MHz speeds; Cyrix/IBM CPUs running at PR120<sup>+</sup>~PR200<sup>+</sup> speeds; and AMD K5/K6 CPUs running at PR75 ~ PR233 speeds
  - Two kinds of mainboards are available: one is the Normal edition which supports above listed CPUs and the other is the IBM CPU attached edition which supports the IBM 6x86 P200<sup>+</sup> CPU only
  - **Supports SOCKET 7 for upgrade**
  - Supports P54C/P55C series SMM Mode and CPU Stop Clock
- L2 Cache Controller
  - Write Back Cache Modes and Direct Mapped Organization
  - On-board 512K Pipeline Burst SRAMs Cache
- DRAM Controller
  - Supports FPM/EDO/Burst EDO/Synchronous – DRAM
  - **Supports 1 strips of 8/16/32 MB Unbuffered DIMMs**
  - On-board memory configurations from **4 to 256 Mbytes**
  - Supports “**Table-Free**” DRAM configuration in any SIMM bank
- BUS Controller
  - Compliant to PCI specifications v2.1
  - Three 32-bit PCI slots (Masters) and four ISA slots, 4-layer PCB
  - **Supports Universal Serial Bus — USB**
- Peripheral Controller
  - System BIOS built-in NCR805 SCSI Card BIOS and “Plug and Play” function
  - On-board built-in PCI Master IDE controller and floppy controller
  - On-board supports for two high speed UARTS (w/i 16550 FIFO), one ECP/EPP/SPP compatible parallel port, and one PS/2 mouse port
  - **On-board supports FLASH Memory for easy upgrade BIOS**

---

## Unpacking the Mainboard

---

The mainboard package contains:

- The EQ82C661X Mainboard
- One CD (Including Manuals/Drivers/Utilities)
- One page of One Sheet Manual

*Note: Do not unpack the mainboard until you are ready to install it.*

Follow the precautions below while unpacking the mainboard.

1. Before handling the mainboard, ground yourself by grasping an unpainted portion of the system's metal chassis.
2. Remove the mainboard from its anti-static packaging and place it on a grounded surface, component side up.
3. Check the mainboard for damage. If any chip appears loose, press carefully to seat it firmly in its socket.

Do not apply power if the mainboard appears damaged. If there is damage to the board contact your dealer immediately.

---

## Electrostatic Discharge Precautions

---

Make sure you ground yourself before handling the mainboard or other system components. Electrostatic discharge can easily damage the components. Note that you must take special precaution when handling the mainboard in dry or air-conditioned environments.

Take these precautions to protect your equipment from electrostatic discharge:

- Do not remove the anti-static packaging until you are ready to install the mainboard and other system components.
- Ground yourself before removing any system component from its protective anti-static packaging. To ground yourself grasp the expansion slot covers or other unpainted portions of the computer chassis.
- Frequently ground yourself while working, or use a grounding strap.
- Handle the mainboard by the edges and avoid touching its components.

## Mainboard Layout w/ Default Settings

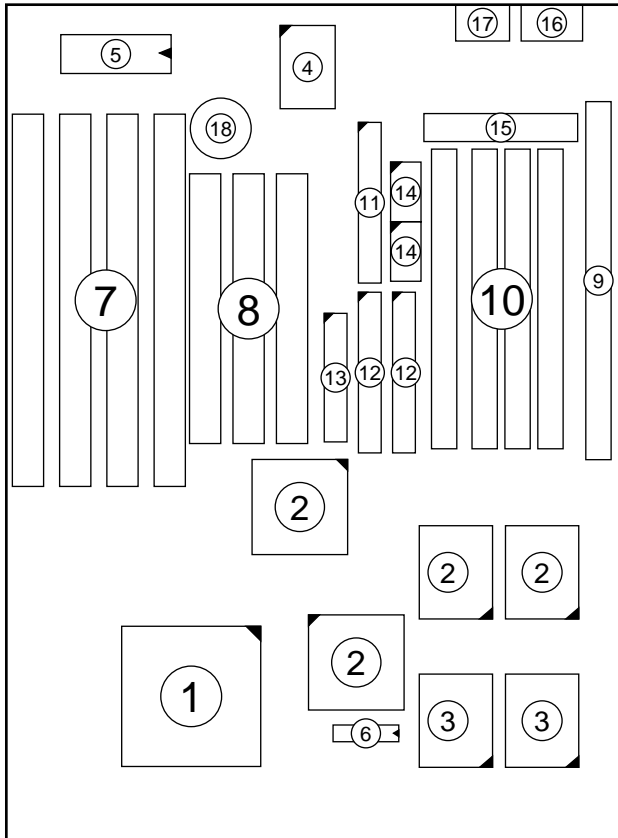

*Figure 1-1. Mainboard Layout*

- |                                 |                             |
|---------------------------------|-----------------------------|
| 1. ZIF socket 7 (for P54C/P55C) | 10. SIMM Bank               |
| 2. EQ82C661X Chipset            | 11. Floppy Connector        |
| 3. Pipelined Burst SRAM         | 12. IDE1/IDE2 Connector     |
| 4. Super I/O Chip               | 13. Parallel Port Connector |
| 5. PnP FLASH BIOS               | 14. COM1/COM2 Connector     |
| 6. TAG SRAM                     | 15. AT Power Connector      |
| 7. ISA Slots                    | 16. KB Connector            |
| 8. PCI Slots                    | 17. PS/2 Mouse Connector    |
| 9. Unbuffered DIMM Bank         | 18. 3 Volt. Lithium Battery |



## Remarks on the Cyrix and IBM P200<sup>+</sup> CPUs

Please note that if you use a Cyrix or IBM P200<sup>+</sup> CPU, you will have to set the frequency to 75MHz. You will also have to set JP16, the PCI bus frequency jumper to asynchronous to have the PCI bus run on 32MHz, in order to avoid problems with add-on cards. If you choose to run the PCI bus on a higher frequency, please use only high-end add-on cards that are specified to function on higher bus frequencies. Please note that using a 75MHz bus clock also places higher demands on the DRAM main-memory, therefore only use high-end SIMM/DIMM modules when this is the case.

### Voltage settings list

Jumpers 30, 31 and 32 set the processor voltage. If you are using a single voltage processor close jp31 and open jp30. Jp31 shorts the processor Vcore voltage pins to the Vio pins when closed. If you use a dual voltage CPU, open jp31 and close jp30.

Jp 32 sets the voltage, please refer to the following table:

voltage	JP32			
	1-2	3-4	5-6	7-8
3.5V	close	close	close	close
3.4V	close	close	close	open
3.3V	close	close	open	close
3.2V	close	close	open	open
3.1V	close	open	close	close
3.0V	close	open	close	open
2.9V	close	open	open	close
2.8V	close	open	open	open
2.7V	open	close	close	close
2.6V	open	close	close	open
2.5V	open	close	open	close
2.4V	open	close	open	open
2.3V	open	open	close	close
2.2V	open	open	close	open
2.1V	open	open	open	close
2.0V	open	open	open	open

# 2 Hardware Setup

This chapter is designed for Normal edition mainboard use only and it explains how to configure the mainboard's hardware. After you install the mainboard, you can set jumpers, install memory on the mainboard, and make case connections. Refer to this chapter whenever you upgrade or reconfigure your system.

---

**CAUTION:** *Turn off power to the mainboard, system chassis, and peripheral devices before performing any work on the mainboard or system.*



---

## Jumpers

---

### JP5: CMOS Clear Jumper

Clear the CMOS memory by momentarily shorting pin 2–3; then shorting pin 1–2 to retain new settings.



CMOS Setting	JP5
Retain CMOS data (default)	 1
Clear CMOS data	 1

### J25: EMI Ground Pin

J25 is designed for eliminating the EMI signals. Short or open J25 when is needed.

### JP16: PCI Bus Asynchronous/Synchronous Jumper

Asynchronous and synchronous (default) PCI bus frequency settings are available.

PCI Bus Setting	JP16
Asynchronous	
Synchronous	

Divides the host bus by 2 to get the Asynchronous setting, and sets the PCI bus on 32MHz to get the synchronous setting. Set JP16 to Synchronous mode when the system is unstable.

Host Bus (CPU Bus)	PCI Bus Frequency (Synchronous)	PCI Bus Frequency (Asynchronous)
50 MHz*	25 MHz	32 MHz
55 MHz*	27.5 MHz	32 MHz
60 MHz	30 MHz	32 MHz
66 MHz	33.3 MHz	32 MHz
75 MHz**	37.5 MHz	32 MHz

\*: Do not use Asynchronous setting when the host bus frequency is 50MHz or 55MHz.

\*\* : Do not use Synchronous setting when the host bus frequency is 75 MHz.

## CPU Type Configuration

This section is designed for normal edition motherboard use only and also shows you how to configure your CPU step by step. Note that you need to check the CPU voltage before installation.

### □ Step 1: Frequency Setting

**Pentium – 75/90/100 CPU Settings (1.5 x clock)**

**AMD K5 – PR75/PR90/PR100/PR120/PR133 (1.5 x clock)**

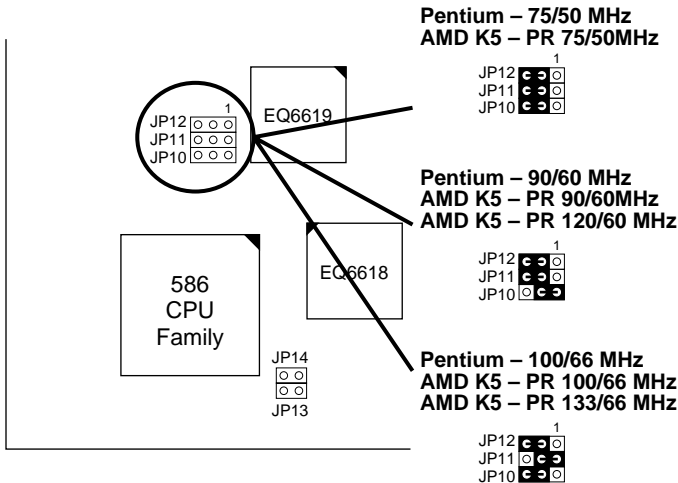

Figure 2-1-1. CPU Jumper Settings

- Note:
1. You must equip the CPU with a fan and heat sink for system stability.
  2. AMD K5-PR75/90= AMD 5<sub>k</sub>86(SSA5)-P75/90.

**P54C/P55C - 100/120/133 CPU Setting (2.0 clock)**

**Cyrix 6x86/6x86L - PR133+/PR150+/PR166+/PR200+ settings (2.0x clock)**

**AMD K5/K6 - PR150 CPU setting**

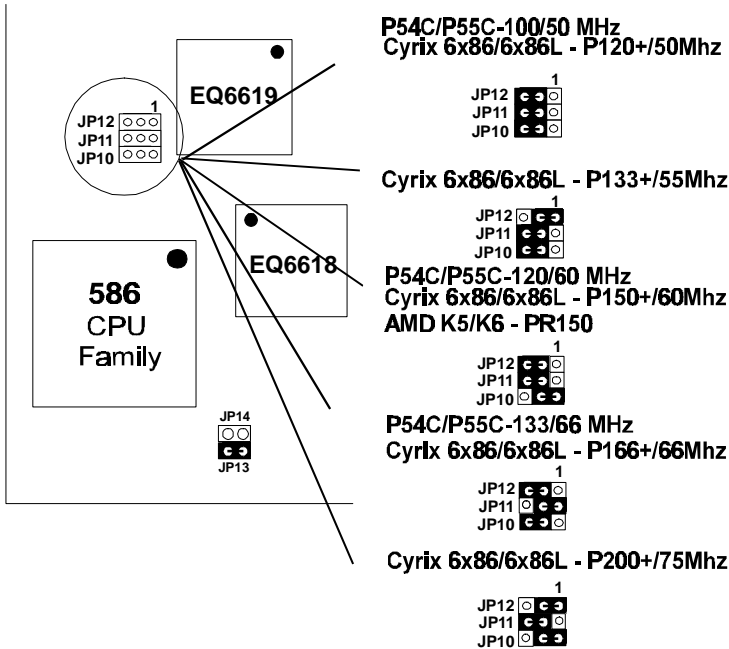

Figure 2-1-2. CPU Jumper Settings

*Note: You must equip the CPU with a fan and heat sink for system stability.*

**Pentium- 150/166 CPU Settings (2.5 x clock)  
AMD K5/K6 – PR166 CPU Setting**

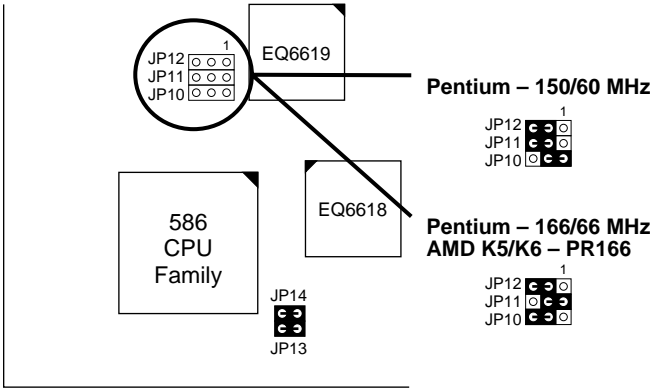

Figure 2-1-3. CPU Jumper Settings

*Note:* You must equip the CPU with a fan and heat sink for system stability.

**Pentium – 180/200 CPU Settings (3.0 x clock)  
AMD K6 – PR200 CPU Setting**

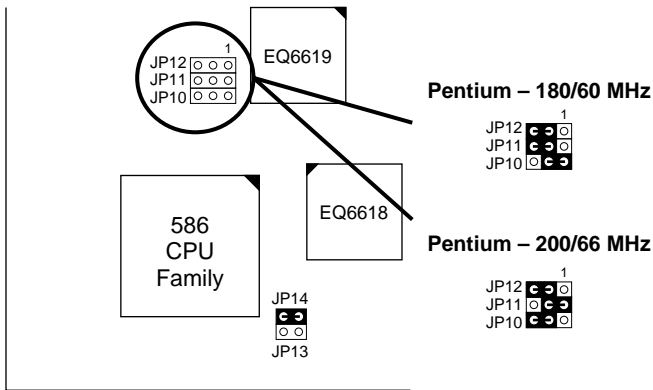

Figure 2-1-4. CPU Jumper Settings

*Note:* You must equip the CPU with a fan and heat sink for system stability.

< 3.5 x clock CPU Setting >

233 MHz CPU Setting

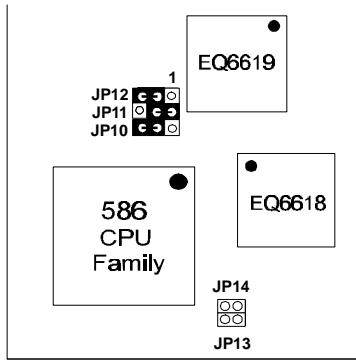

Figure 2-1-2. CPU Jumper Settings

Note: You must equip the CPU with a fan and heat sink for system stability.

<4.0 x clock CPU Setting >

266 MHz CPU Setting

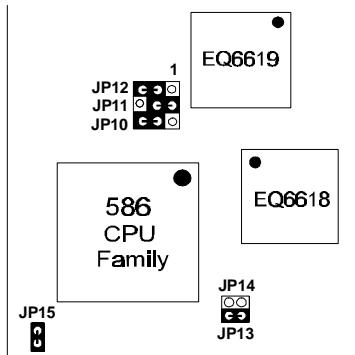

Figure 2-1-3. CPU Jumper Settings

Note: You must equip the CPU with a fan and heat sink for system stability.

## □ Step 2: CPU Single/Dual Voltage Setting

### Single Voltage CPU Setting

Single voltage CPUs use the same voltage for both Vio and Vcore. The CPUs that fall into this category are : P54CX , AMD-K5 and the Cyrix 6x86. Refer to the following figures to set the voltage for these CPUs:

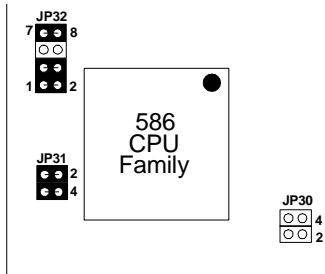

Figure 2-2-1. Single Voltage 3.3V CPU

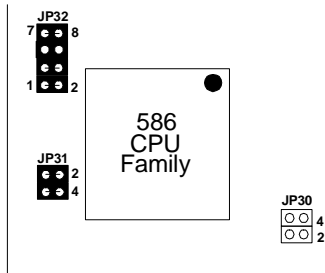

Figure 2-2-2. Single Voltage 3.5V CPU (Default)

### Dual Voltage CPU Setting

Dual voltage CPUs are designed to use different voltages for Vio and Vc ore. They include P55CX and the Cyrix 6x86L / 6x86MX. Refer to the following figure to set the voltage for these CPUs:

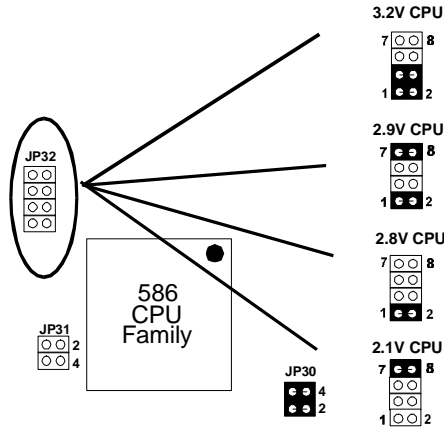

Figure 2-2-3 Dual Voltage CPU

*Note: Due to varying designs, please ask your dealer for the correct voltage settings for your specific CPU.*

### Memory Configuration

The mainboard supports two banks of 72-pin FPM/EDO/Burst EDO DRAM (SIMM) and one 3.3V Unbuffered DIMM module. The mainboard requires SIMMs of at least 70ns access time.

The mainboard supports from 4 to 256 Mbytes of memory with no restrictions on memory configurations. You can install SIMMs in any combination without having to rely on a memory configuration table. Memory configurations are thus 'table-free' in any SIMM bank. You do however need to install two SIMM modules to complete a bank.

### Memory Configuration Table

	SIMM Bank		DIMM Bank
	Bank 1	Bank 2	DIMM
RAM Type	FPM/EDO/BEDO (DRAM)	FPM/BEDO (DRAM)	FPM/EDO/SDRAM
Single RAM Module Size (MB)	4/8/16/32	4/8/16/32	8/16/32

*Note : Do not install FPM/EDO/BEDO SIMM when you already installed SDRAM type of DIMM.*

### RAM Bank Installation Notice

Due to the RAS line share architecture of ETEQ chipset, the possible combination of DIMM/SIMM in the mainboard are as one of the following :

1. In Bank 1
2. In Bank 2
3. In Bank 1 & Bank 2
4. In DIMM
5. In Bank 2 & DIMM

### Cache Configuration

The mainboard has a write-back caching scheme with built-in 512KB level - 2 Pipelined Burst Cache onboard to improve the system performance.

### Cache Size and RAM Location

Cache Size	Cache RAM	TAG RAM	Cacheable Range
512KB	64K x 32, 2 pcs on U19,U20	16 K x 8 on U21	64 MB

---

## Multi I/O Port Addresses

---

Default settings for multi I/O port addresses are shown in the table below.

Port	I/O Address	IRQ	Status
<b>LPT1*</b>	378H	7	ECP + EPP
<b>COM1</b>	3F8H	4	
<b>COM2</b>	2F8H	3	

If default I/O port addresses conflict with other I/O cards (e.g. sound cards or I/O cards), you must adjust one of the I/O addresses to avoid address conflict. (You can adjust these I/O addresses from the BIOS)

*Note: Some sound cards have a default IRQ setting for IRQ7, which may conflict with printing functions. If this occurs do not use sound card functions at the same time you print.*

---

## Connectors

---

Attach the mainboard to case devices via connectors on the mainboard. Refer to Figure 1-1 for connector locations and connector pin positions.

### COM1, COM2 - COM1/COM2 Connectors

Attach COM1/COM2 device to these connectors.

### FDC Connector

Attach floppy cable to this connector.

### J19 - Hardware Reset Control

Attach the reset switch to J19. Closing the Reset switch restarts the system.

### J24 - HDD LED Connector

Attach the cable of hard disk drive LED to this connector. The LED lights when an HDD is active.

### CN5 - IR Connector

Attach a 5-pin infrared device cable to this connector for enabling the infrared transfer function. This mainboard meets the specification of ASKIR and HPSIR.

### CN2 - Keyboard Connector

A 5-pin female DIN keyboard connector is located at the rear of the board. Plug the keyboard jack into this connector.

### J17 - Keylock & Power LED Connector

J17 is a connector for a lock that may be installed on the system case for enabling or disabling the keyboard. J17 also attaches to the case's Power LED. (Pin 1,3 for power LED and pin 4,5 for keylock.)

### IDE1/IDE2 - Onboard Primary/Secondary IDE HDD Connectors

Attach cable of hard disk drives to these connectors.

### CN1 - PS/2 Mouse Connector

Attach PS/2 mouse cable to this connector.

### PRT - Parallel Port Connector

Attach parallel port cable to this connector.

### PW - AT Power Supply Connector

The mainboard requires a power supply with at least 200 watts and a "power good" signal. PW has two 6-pin male header connectors. Plug the dual connectors from the power directly onto the board connector while making sure the black leads are in the center.

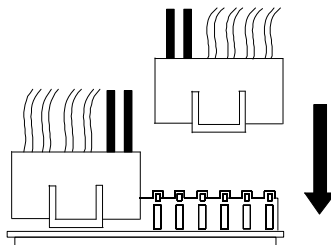

### J23: Sleep Switch Connector Enable/Disable

Toggle this jumper to force the system into power saving (green) mode. Any hardware IRQ signal will cause the system to wake up.

### CN3: Universal Serial Bus Connectors

Attach a 9 pin USB cable to these connectors to connect external USB devices to the mainboard.

### J18: Speaker Connector

Attach the connector from the speaker in your case to this jumper.

# 3 BIOS Setup

The mainboard's BIOS setup program is the ROM PCI/ISA BIOS from Award Software Inc. Enter the Award BIOS program's Main Menu as follows:

1. Turn on or reboot the system. After a series of diagnostic checks, you are asked to press DEL to enter Setup.
2. Press the <DEL> key to enter the Award BIOS program and the main screen appears:

ROM PCI/ISA BIOS  
CMOS SETUP UTILITY  
AWARD SOFTWARE, INC.

STANDARD CMOS SETUP	INTEGRATED PERIPHERALS
BIOS FEATURES SETUP	SUPERVISOR PASSWORD
CHIPSET FEATURES SETUP	USER PASSWORD
POWER MANAGEMENT SETUP	IDE HDD AUTO DETECTION
PNP/PCI CONFIGURATION	SAVE & EXIT SETUP
LOAD SETUP DEFAULTS	EXIT WITHOUT SAVING
LOAD BIOS DEFAULTS	
Esc : Quit	↑ ↓ → ← : Select Item
F10 : Save & Exit Setup	(Shift) F2 : Change Color
Time, Date, Hard Disk Type...	

3. Choose an option and press <Enter>. Modify the system parameters to reflect the options installed in the system. (See the following sections.)
4. Press <ESC> at anytime to return to the Main Menu.
5. In the Main Menu, choose "SAVE AND EXIT SETUP" to save your changes and reboot the system. Choosing "EXIT WITHOUT SAVING" ignores your changes and exits the program.

The Main Menu options of the Award BIOS are described in the sections that follow.

## Standard CMOS Setup

Run the Standard CMOS Setup as follows.

1. Choose “STANDARD CMOS SETUP” from the Main Menu. A screen appears.

ROM PCI/ISA BIOS  
STANDARD CMOS SETUP  
AWARD SOFTWARE, INC.

Date (mm:dd:yy) : Fri, Feb 1 1995							
Time (hh:mm:ss) : 7 : 30 : 33							
HARD DISKS	TYPE	SIZE	CYLS	HEAD	PRECOMP	LANDZ	SECTOR MODE
Primary Master	: AUTO	0	0	0	0	0	0 AUTO
Primary Slave	: None	0	0	0	0	0	0 ----
Secondary Master	: None	0	0	0	0	0	0 ----
Secondary Slave	: None	0	0	0	0	0	0 ----
Drive A : 1.44M, 3.5 in.				Base Memory: 640K Extended Memory: 3328K Other Memory: 128K			
Drive B : None							
Video : EGA/VGA				Total Memory: 4096K			
Halt On : All Errors							
Esc : Quit		↑ ↓ → ← : Select Item		PU/PD/+/- : Modify			
F11 : Help		(Shift) F2 : Change Color		F3 : Toggle Calendar			

2. Use arrow keys to move between items and select values. Modify selected fields using PgUp/PgDn/+/- keys. Some fields let you enter values directly.

**Date (mm/dd/yy)** Type the current date.

**Time (hh:mm:ss)** Type the current time.

**Primary (Secondary)** First, choose the type of hard disk that you already installed:

- Master & Slave**
- Auto – BIOS detects hard disk type automatically (default)
  - 1 ~ 46 – Selects standard hard disk type
  - User – User defines the type of hard disk.

Next, choose hard disk mode:

- Auto – BIOS detects hard disk mode automatically (default)
- Normal – Normal IDE hard disk (smaller than 528MB)
- LBA – Enhanced-IDE hard disk (larger than 528MB)

<b>Primary (Secondary) Master &amp; Slave (Continued)</b>	Large – Large IDE hard disk (for certain hard disk)  <i>Note: If you have any questions on your hard disk type or mode, ask your hard disk provider or previous user for details.</i>
<b>Drive A &amp; B</b>	Choose 360KB , 5 1/4 in., 1.2MB , 5 1/4 in., 720KB , 3 1/2 in., 1.44M , 3 1/2 in.(default), 2.88 MB, 3 1/2 in. or Not installed
<b>Video</b>	Choose Monochrome, Color 40x25, VGA/EGA (default), Color 80x25
<b>Halt On</b>	When BIOS detects system errors, this function will stop the system. Choose one of the following options to make system halt.  All Errors (default)        All, But Diskette No Errors                      All, But Keyboard   All, But Disk/Key

3. When you finish, press the <ESC> key to return to the Main Menu.

## BIOS Features Setup

Run the BIOS Features Setup as follows.

1. Choose “BIOS FEATURES SETUP” from the Main Menu and a screen with a list of items appears. (The screen below shows the BIOS default settings.)

ROM PCI/ISA BIOS  
BIOS FEATURES SETUP  
AWARD SOFTWARE, INC.

CPU Internal Cache	: Enabled	Video BIOS Shadow	: Enabled
External Cache	: Enabled	C8000-CBFFF Shadow	: Disabled
Quick Power on Self Test	: Enabled	CC000-CFFFF Shadow	: Disabled
Boot Sequence	: A,C,SCSI	D0000-D3FFF Shadow	: Disabled
Swap Floppy Drive	: Disabled	D4000-D7FFF Shadow	: Disabled
Boot Up NumLock Status	: On	D8000-DBFFF Shadow	: Disabled
Typematic Rate Setting	: Disabled	DC000-DFFFF Shadow	: Disabled
Typematic Rate (Chars/Sec)	: 6		
Typematic Delay (Msec)	: 250		
Security Option	: Setup	ESC : Quit	↑ ↓ → ← : Select Item
IDE Second Channel Control	: Enabled	F1 : Help	PU/PD/+/- : Modify
PS/2 Mouse Function Control	: Disabled	F5 : Old Values (Shift)	F2 : Color
PCI/VGA Palette Snoop	: Disabled	F6 : Load BIOS Defaults	
OS Select for DRAM >64MB	: Non-OS2	F7 : Load Setup Defaults	

2. Use the arrow keys to move between items and to select values. Modify the selected fields using the PgUp/PgDn/+/- keys. <F> keys are explained below:
  - <F1>: “Help” gives options available for each item.
  - Shift <F2>: Change color.
  - <F5>: Get the old values. These values are the values with which the user started the current session.
  - <F6>: Load all options with the BIOS Setup default values.
  - <F7>: Load all options with the Power-On default values.

A short description of screen items follows:

**CPU Internal Cache** This option enables/disables the CPU’s internal cache. (The Default setting is Enabled.)

**External Cache** This option enables/disables the external cache memory. (The Default setting is Enabled.)

**Quick Power On Self Test** Enabled provides a fast POST at boot-up .

- Boot Sequence** Choose the boot device sequence as your need. For example, “A, C, SCSI” means BIOS will look for an operating system first from drive A, drive C, then SCSI device. Options of this function are:  
 A, C, SCSI  
 C, A, SCSI  
 C, CD-ROM, A  
 CD-ROM, C, A  
 D, A, SCSI  
 E, A, SCSI  
 F, A, SCSI  
 SCSI, A, C  
 SCSI, C, A  
 C only.
- Swap Floppy Drive** Enabled changes the sequence of the A: and B: drives. (The Default setting is Disabled.)
- Boot Up Num Lock Status** Choose **On** or **Off**. On puts numeric keypad in Num Lock mode at boot-up. Off puts this keypad in arrow key mode at boot-up.
- Typematic Rate Setting** Enable this option to adjust the keystroke repeat rate.
- Typematic Rate (Chars/Sec)** Choose the rate a character keeps repeating.
- Typematic Delay (Msec)** Choose how long after you press a key that a character begins repeating.
- Security Option** Choose **Setup** or **System**. Use this feature to prevent unauthorized system boot-up or use of BIOS Setup.
- “System” – Each time the system is booted the password prompt appears.
- “Setup” – If a password is set, the password prompt only appears if you attempt to enter the Setup program.

<b>IDE Second Channel Control</b>	Default setting is Enabled. Choose Disabled when you need to turn off the onboard IDE second channel.
<b>PS/2 Mouse Function Control</b>	Default setting is Disabled. You need to enable this function when the PS/2 mouse is attached.
<b>PCI/VGA Palette Snoop</b>	Enabled: The color of the monitor may be incorrect if uses with MPEG card. Enable this option to make the monitor normal.  Disabled: Default setting.
<b>OS Select for DRAM &gt;64MB</b>	OS2 – Choosing this when you are using OS/2 operation system.  Non-OS/2 – Choosing this when you are using no-OS/2 operation system.
<b>Video or Adapter BIOS Shadow</b>	BIOS shadow copies BIOS code from slower ROM to faster RAM. BIOS can then execute from RAM. These 16K segments can be shadowed from ROM to RAM. BIOS is shadowed in a 16K segment if it is enabled and it has BIOS present.

3. After you have finished with the BIOS Features Setup program, press the <ESC> key and follow the screen instructions to save or disregard your settings.

## Chipset Features Setup

The Chipset Features Setup option changes the values of the chipset registers. These registers control system options in the computer.

*Note:* Change these settings only if you are familiar with the Chipset.

Run the Chipset Features Setup as follows.

1. Choose “CHIPSET FEATURES SETUP” from the Main Menu and the following screen appears. (The screen below shows default settings.)

ROM PCI/ISA BIOS CHIPSET FEATURES SETUP AWARD SOFTWARE, INC.	
DRAM Auto Configuration : 60 ns DRAM Timing Control : Auto  Read Pipeline : Disabled Write Pipeline : Enabled  Video BIOS Cacheable : Disabled System BIOS Cacheable : Disabled Memory Hole At 15Mb Addr.: Disabled  OnChip USB : Disabled	ESC : Quit           ↑ ↓ → ←: Select Item F1 : Help           PU/PD/+/- : Modify F5 : Old Values (Shift)F2 : Color F6 : Load BIOS Defaults F7 : Load Setup Defaults

2. Use the arrow keys to move between items and select values. Modify selected fields using the PgUp/PgDn/+/- keys.

A short description of screen items follows:

**DRAM Auto Configuration** Choose **60ns** (default) or **70ns** when the DRAM Timing Control needs to be set to Auto; and; when choose **Disabled**, the DRAM Timing Control can be set to Normal, Medium, Fast, or Turbo.

**DRAM Timing Control** Choose Auto, Normal, Medium, Fast, or Turbo. BIOS sets the DRAM Timing automatically when this function is set to Auto. Normal is the slowest and you must check the system stability before you change to the Fast or Turbo setting, otherwise it should be on Auto.

- 
- |                                 |  |
|---------------------------------|--|
| <b>SDRAM Cycle Length</b>       | 2 (default). This function is shown only when uses SDRAM.  |
| <b>Read Pipeline</b>            | Use the default setting.   |
| <b>Write Pipeline</b>           | Use the default setting.   |
| <b>Video BIOS Cacheable</b>     | Disabled – The ROM area F0000H-FFFFFH is not cached.<br><br>Enabled – The ROM area F0000H-FFFFFH is cacheable if cache controller is enabled.  |
| <b>System BIOS Cacheable</b>    | Disabled – The video BIOS C0000H-C7FFFH is not cached.<br><br>Enabled – The video BIOS C0000H-C7FFFH is cacheable if cache controller is enabled.                                    |
| <b>Memory Hole At 15Mb Addr</b> | Choose <b>Enabled</b> or <b>Disabled</b> (default). Some interface cards will map their ROM address to this area. If this occurs, you should select Enabled, otherwise use Disabled. |
| <b>OnChip USB</b>               | Default is Disabled. Enable this function when you use the USB device.   |
| <b>USB Keyboard Support</b>     | Enable this function when you use the USB keyboard, but notice that you need to use the regular keyboard first before getting in the BIOS setup.                                     |
3. After you have finished with the Chipset Features Setup, press the <ESC> key and follow the screen instructions to save or disregard your settings.

## Power Management Setup

The Power Management Setup option sets the system's power saving functions.

Run the Power Management Setup as follows.

1. Choose "POWER MANAGEMENT SETUP" from the Main Menu and a screen with a list of items appears.

ROM PCI/ISA BIOS CMOS SETUP UTILITY POWER MANAGEMENT SETUP	
Power Management : Disabled	** Power Down & Resume Events **
PM Control by APM : Yes	IRQ 5 (LPT 2) : Primary
Video Off Option : Suspend -> Off	IRQ 6 (Floppy Disk) : Primary
Video Off Method : V/H SYNC+Blank	IRQ 7 (LPT 1) : Primary
Conserve Mode : Disabled	IRQ 8 (RTC Alarm) : Disabled
	IRQ 9 (IRQ2 Redir) : Secondary
** PM Timers **	IRQ 10 (Reserved) : Secondary
HDD Power Down : Disabled	IRQ 11 (Reserved) : Secondary
Doze Mode : Disabled	IRQ 12 (PS/2 mouse) : Primary
Suspend Mode : Disabled	IRQ 13 (Coprocessor) : Primary
	IRQ 14 (Hard Disk) : Primary
** PM Events **	IRQ 15 (Reserved) : Disabled
VGA : OFF	ESC : Quit           ↑ ↓ → ← : Select Item
LPT & COM : LPT/COM	F1 : Help           PU/PD/+/- : Modify
HDD & FDD : ON	F5 : Old Values (Shift) F2 : Color
DMA/master : OFF	F6 : Load BIOS Defaults
Primary INTR : ON	F7 : Load Setup Defaults
IRQ 3 (COM 2) : Primary	
IRQ 4 (COM 1) : Primary	

2. Use the arrow keys to move between items and to select values. Modify the selected fields using the PgUp/PgDn/+/- keys.

A short description of selected screen items follows:

<b>Power Management</b>	Options are as follows:
User Define –	Let's you define the HDD and system power down times.
Disabled –	Disables the Green PC Features.
Min Saving –	Doze timer = 1 Hour Suspend timer = 1 Hour HDD Power Down = 15 Min
Max Saving –	Doze timer = 10 Sec Suspend timer = 10 Sec HDD Power Down = 1 Min

---

<b>PM Control by APM</b>	Choose <b>Yes</b> (default) or <b>No</b> . APM stands for Advanced Power Management. To use APM, you must run “power.exe” under DOS v6.0 or later version.
<b>Video Off Option</b>	Susp, Stby→off: Video off when the system runs into Suspend or Standby mode.  All Modes→off: Video off in all modes.  Always On: Video never off.  Suspend→off: Video off when system runs into the suspend mode.
<b>Video Off Method</b>	Choose <b>V/H Sync+Blank</b> (default), <b>Blank screen</b> , or <b>DPMS</b> for the selected PM mode.
<b>Conserve Mode</b>	Use the default setting.
<b>HDD Power Down</b>	When the set time has elapsed, the BIOS sends a command to the HDD to power down, which turns off the motor. Time is adjustable from 1 to 15 minutes. The default setting is Disabled. Some older model HDDs may not support this advanced function.
<b>Doze Mode</b>	When the set time has elapsed, the BIOS sends a command to the system to enter doze mode (system clock drops to 33MHz). Time is adjustable from 10 seconds to 1 Hour.
<b>Suspend Mode</b>	The default is Disabled. Only an SL-Enhanced (or SMI) CPU can enter this mode. Time is adjustable from 10 seconds to 1 Hour. Under Suspend mode, the CPU stops completely (no instructions are executed.)
<b>VGA</b>	Choose <b>Off</b> (default) or <b>On</b> to disable or enable the power management.

---

<b>LPT &amp; COM</b>	Choose LPT/COM (default) or LPT (COM) to enable the power management timer. Choose NONE to disable the power management timer.
<b>HDD &amp; FDD</b>	Choose <b>On</b> (default) to enable the power management timer, or <b>Off</b> to disable the power management timer.
<b>DMA/master</b>	Choose <b>Off</b> (default) or <b>On</b> . If you choose the system “Off”, will not monitor the signal of DMA/master; and when you choose “On”, the system will not have SMI signal until the master is finished while the master is working.
<b>Primary INTR</b>	When <b>On</b> (default) is chosen, you can choose any IRQ #.
<b>IRQ#</b>	When set at “Primary” the processor will power down only after the BIOS detects a “no IRQ activity” during the time specified by the Suspend time. If set at “Secondary event” the system will distinguish whether an interrupt accesses and I/O address or not. If it does, the system enters the standby mode. If not, the system enters the dreaming mode; that is the system goes back full-on status but leaves the monitor blank. For instance, if the system connects to a LAN and receives an interrupt from its file server, the system will enter the dreaming mode to execute the corresponding calling routine.

3. After you have finished with the Power Management Setup, press the <ESC> key to return to the Main Menu.

## PNP/PCI Configuration Setup

This option sets the mainboard's PCI Slots. Run this option as follows:

1. Choose "PNP/PCI CONFIGURATION SETUP" from the Main Menu and the following screen appears. (The screen below shows default settings.)

```
ROM PCI/ISA BIOS
PNP/PCI CONFIGURATION
AWARD SOFTWARE, INC.
```

<pre>Resources Controlled By : Manual Reset Configuration Data : Disabled  IRQ-3 assigned to : Legacy ISA* IRQ-4 assigned to : Legacy ISA* IRQ-5 assigned to : PCI/ISA PnP* IRQ-7 assigned to : PCI/ISA PnP* IRQ-9 assigned to : PCI/ISA PnP* IRQ-10 assigned to : PCI/ISA PnP* IRQ-11 assigned to : PCI/ISA PnP* IRQ-12 assigned to : PCI/ISA PnP* IRQ-14 assigned to : PCI/ISA PnP* IRQ-15 assigned to : PCI/ISA PnP* DMA-0 assigned to : PCI/ISA PnP* DMA-1 assigned to : PCI/ISA PnP* DMA-3 assigned to : PCI/ISA PnP* DMA-5 assigned to : PCI/ISA PnP* DMA-6 assigned to : PCI/ISA PnP* DMA-7 assigned to : PCI/ISA PnP*</pre>	<pre>PCI IRQ Activated By : Level PCI IDE IRQ Map To : PCI-AUTO Primary IDE INT# : A Secondary IDE INT# : B  ESC : Quit          ↑↓→←: Select Item F1 : Help          PU/PD/+/- : Modify F5 : Old Values (Shift)F2 : Color F6 : Load BIOS Defaults F7 : Load Setup Defaults</pre>
---	---

\*: *These items will disappear when Resource Controlled. is Auto.*

2. Use the arrow keys to move between items and select values. Modify selected fields using the PgUp/PgDn/+/- keys.

A short description of screen items follows:

- |                                 |  |
|---------------------------------|--|
| <b>Resources Controlled By</b>  | Manual – BIOS doesn't manage PCI/ISA PnP card (i.e., IRQ) automatically. |
|                                 | Auto – BIOS auto manage PCI and ISA PnP card (recommended).              |
| <b>Reset Configuration Data</b> | Disabled – Retain PnP configuration data in BIOS.                        |
|                                 | Enabled – Reset PnP configuration data in BIOS.                          |

- 
- |                                 |  |
|---------------------------------|--|
| <b>IRQX and DMA assigned to</b> | Choose <b>PCI/ISA PnP</b> or <b>Legacy ISA</b> . If the first item is set to Manual, you could choose IRQX and DMA assigned to PCI/ISA PnP card or ISA card.   |
| <b>PCI IRQ Activated By</b>     | Choose <b>Edge</b> or <b>Level</b> . Most PCI trigger signals are Level. This setting must match the PCI card.   |
| <b>PCI IDE IRQ Map To</b>       | Select <b>PCI-AUTO</b> , <b>ISA</b> , or <b>assign a PCI SLOT number</b> (depending on which slot the PCI IDE is inserted). The default setting is PCI-AUTO. If PCI-AUTO does not work, then assign an individual PCI SLOT number. |
| <b>Primary IDE INT#</b>         | Choose INTA#, INTB#, INTC#, or INTD#. The default setting is INTA#.  |
| <b>Secondary IDE INT#</b>       | Choose INTA#, INTB#, INTC#, or INTD#. The default setting is INTB#.  |
3. After you have finished with the PCI Slot Configuration, press the <ESC> key and follow the screen instructions to save or disregard your settings.

## Load Setup Defaults

---

This item loads the system values you have previously saved. Choose this item and the following message appears:

“Load SETUP Defaults (Y/N)? N”

To use the SETUP defaults, change the prompt to “Y” and press <Enter>. This item is recommended if you need to reset the system setup.

*Note: The SETUP Defaults are optimized for the most stabilized performance.*

## Load BIOS Defaults

---

Choose this item and the following message appears:

“Load BIOS Defaults (Y/N)?N”

To use the BIOS defaults, change the prompt to “Y” and press <Enter>.

*Note: BIOS DEFAULTS values are adjusted for high performance. If you run into any problems after loading BIOS DEFAULTS, please load the SETUP DEFAULTS for the stable performance.*

## Integrated Peripherals

The Integrated Peripherals option changes the values of the chipset registers. These registers control system options in the computer.

*Note:* Change these settings only if you are familiar with the Chipset.

Run the Integrated Peripherals as follows.

1. Choose “Integrated Peripherals” from the Main Menu and the following screen appears. (The screen below shows default settings:)

ROM PCI/ISA BIOS INTEGRATED PERIPHERALS AWARD SOFTWARE, INC.	
OnChip IDE First Channel : Enabled	
OnChip IDE Second Channel: Enabled	
IDE Prefetch Mode : Enabled	
IDE HDD Block Mode : Enabled	
IDE Primary Master PIO : Auto	
IDE Primary Slave PIO : Auto	
IDE Secondary Master PIO : Auto	
IDE Secondary Slave PIO : Auto	
IDE Secondary Master UDMA: Auto	
IDE Secondary Slave UDMA: Auto	
Onboard FDC Controller : Enabled	
Onboard UART 1 : 3F8/IRQ4	
Onboard UART 2 : 2F8/IRQ3	
Onboard UART 2 Mode : Standard	
Onboard Parallel Port : 378/IRQ7	
Parallel Port Mode : ECP+EPP	
ECP Mode Use DMA : 3	
Parallel Port EPP Type : EPP1.9	
ESC : Quit                   ↑ ↓ → ← : Select Item F1 : Help                    PU/PD/+/- : Modify F5 : Old Values (Shift)F2 : Color F6 : Load BIOS Defaults F7 : Load Setup Defaults	

2. Use the arrow keys to move between items and select values. Modify selected fields using the PgUp/PgDn/+/- keys.

A short description of screen items follows:

<b>On-chip IDE First Channel/</b>	Enabled – Use the on-board IDE (default)
<b>On-chip IDE Second Channel</b>	Disabled – Turn off the on-board IDE
<b>IDE Prefetch Mode</b>	Use the default setting.
<b>IDE HDD Block Mode</b>	Choose <b>Enabled</b> (default) or <b>Disabled</b> . Enabled invokes multi-sector transfer instead of one sector per transfer. Not all HDDs support this function.

<b>IDE Primary Master PIO/ IDE Primary Slave PIO/ IDE Secondary Master PIO/ IDE Secondary Slave PIO</b>	Choose <b>Auto</b> (default) or <b>mode 0~4</b> . Mode 0 is the slowest speed, and HDD mode 4 is the fastest speed. For better performance and stability, we suggest you use the Auto setting to set the HDD control timing.
<b>IDE Secondary Master UDMA IDE Secondary Slave UDMA</b>	Choose <b>Auto</b> (default) or <b>Disabled</b> . When Auto is selected, it supports Ultra DMA Mode.
<b>Onboard FDC Controller</b>	Enabled – Use the on-board floppy controller (default). Disabled – Turn off the on-board floppy controller.
<b>Onboard UART 1/ Onboard UART 2</b>	Choose serial port 1 & 2's I/O address. Do not set port 1 & 2 to the same value except for Disabled.  COM 1/3F8H   COM3/3E8H COM 2/2F8H   COM4/2E8H (default)
<b>Onboard UART 2 Mode</b>	Standard – (default) supports a serial infrared IrDA.  HPSIR – supports HP serial infrared interface format  ASKIR – supports a Sharp serial interface format.
<b>IR Duplex Mode</b>	Use the default setting (Half). This function shows up only when either HPSIR or ASKIR is chosen in the previous function (Onboard UART 2 Mode).
<b>Onboard Parallel Port</b>	Choose the printer I/O address: 378H/IRQ7 (default), 3BCH/IRQ7, 278H/IRQ5

- Parallel Port Mode** Choose **ECP + EPP** (default), **Normal** or **EPP**, **ECP** mode. The mode depends on your external device that connects to this port.
- ECP Mode Use DMA** Choose **DMA3** (default) or **DMA1**. This setting only works when the Onboard Printer Mode is set at the ECP mode.
- Parallel Port EPP Type** Choose EPP specification Ver. 1.7 or 1.9 (default).

## Supervisor Password

---

Based on the setting you made in the “Security Option” of the “BIOS FEATURES SETUP”, this Main Menu item lets you configure the system so that a password is required every time the system boots or an attempt is made to enter the Setup program. Change the password as follows:

1. Choose “SUPERVISOR PASSWORD” in the Main Menu and press <Enter>. The following message appears:

**“Enter Password:”**

2. Enter a password and press <Enter>. (If you do not wish to use the password function, you can just press <Enter> and a “Password disabled” message appears. )
3. After you enter your password, the following message appears prompting you to confirm the new password:

**“Confirm Password:”**

4. Re-enter your password and then Press <ESC> to exit to the Main Menu.

***Important:*** *If you forget or lose the password, the only way to access the system is to set jumper JP5 to clear the CMOS RAM. All setup information is lost and you must run the BIOS setup program again.*

---

## User Password

---

Based on the setting you made in the “Security Option” of the “BIOS FEATURES SETUP”, this Main Menu item lets you configure the system so that a password is required every time the system boots or an attempt is made to enter the Setup program. Change the password as follows:

1. Choose “USER PASSWORD” in the Main Menu and press <Enter>. The following message appears:

**“Enter Password:”**

2. Enter a password and press <Enter>. (If you do not wish to use the password function, you can just press <Enter> and a “Password disabled” message appears. )
3. After you enter your password, the following message appears prompting you to confirm the new password:

**“Confirm Password:”**

4. Re-enter your password and then Press <ESC> to exit to the Main Menu.
5. You are not allowed to change any setting in “CMOS SETUP UTILITY” except change user’s password.

***Important: If you forget or lose the password, the only way to access the system is to set jumper JP5 to clear the CMOS RAM. All setup information is lost and you must run the BIOS setup program again.***

## IDE HDD Auto Detection

This Main Menu item automatically detects the hard disk type and configures the STANDARD CMOS SETUP accordingly.

*Note: This function is only valid for IDE hard disks.*

ROM PCI/ISA BIOS  
CMOS SETUP UTILITY  
AWARD SOFTWARE, INC.

HARD DISKS	TYPE	SIZE	CYLS	HEAD	PRECOMP	LANDZ	SECTOR	MODE
Primary Master	: None	0	0	0	0	0	0	----
Primary Slave	: None	0	0	0	0	0	0	----
Secondary Master	: None	0	0	0	0	0	0	----
Secondary Slave	: None	0	0	0	0	0	0	----

Do you accept this drive C (Y/N)? N

ESC : Skip

# Appendix A

## Jumper for Cyrix/IBM CPU (J100)

The SY-5EAS mainboard has a new jumper (J100) for better performance with Cyrix/IBM CPUs. Here is explanation for you on how to use this jumper correctly.

- Leave J100 open when you want to install a non-Cyrix /IBM CPU (default setting), or short J100 when you want to install a Cyrix CPU.

If you use a Cyrix/IBM CPU, do the following steps :

- (1) Press [DELETE] to enter BIOS setup menu during boot-up.
- (2) Select “ Chipset Features Setup ”
- (3) Set “Linear Burst” to “Enabled” then choose “SAVE & EXIT SETUP”

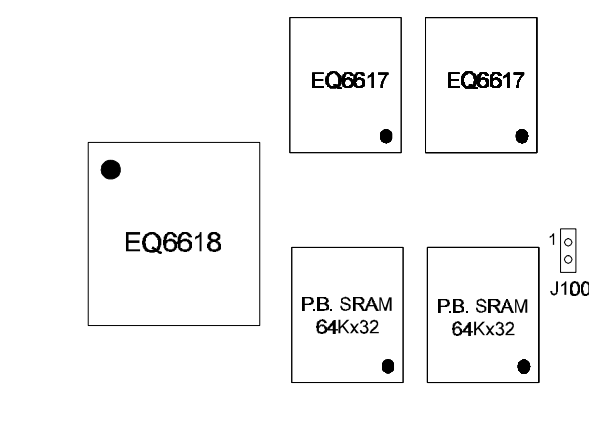

**Figure 1** Location of J100



## Quick Installation Guide (continued)

**Table 3 : Settings for various processors**

SETTINGS		CPU Frequency JP10, 11, 12 / JP 13, 14						
processor	bus clock	multiplier	JP10	JP11	JP12	JP13	JP14	
AMD K5 PR75	50 Mhz	1.5x	2-3	2-3	2-3	open	open	
AMD K5 PR90	60 Mhz	1.5x	1-2	2-3	2-3	open	open	
AMD K5 PR100	66 Mhz	1.5x	2-3	1-2	2-3	open	open	
AMD K5 PR120	60 Mhz	1.5x	1-2	2-3	2-3	open	open	
AMD K5 PR133	66 Mhz	1.5x	2-3	1-2	2-3	open	open	
AMD K5 PR150	66 Mhz	1.5x	2-3	1-2	2-3	open	open	
AMD K5 PR166	66 Mhz	2.5x	2-3	1-2	2-3	close	close	
AMD K6 PR166	66 Mhz	2.5x	2-3	1-2	2-3	close	close	
AMD K6 PR200	66 Mhz	3x	2-3	1-2	2-3	open	close	
AMD K6 PR233	66 Mhz	3.5x	2-3	1-2	2-3	open	open	
Cyrix 6x86(L) P133+	55 Mhz	2.0x	2-3	2-3	2-3	close	open	
Cyrix 6x86(L) P150+	60 Mhz	2.0x	1-2	2-3	2-3	close	open	
Cyrix 6x86(L) P166+	66 Mhz	2.0x	2-3	1-2	2-3	close	open	
Cyrix 6x86(L) P200+	75 Mhz	2.0x	1-2	2-3	1-2	close	open	
Cyrix MX PR166	60 Mhz	2.5x	1-2	2-3	2-3	close	close	
Cyrix MX PR200	66 Mhz	2.5x	2-3	1-2	2-3	close	close	
Cyrix MX PR233	75 Mhz	2.5x	1-2	2-3	1-2	close	close	
Cyrix MX PR266	75 Mhz	3x	1-2	2-3	1-2	open	close	
P54C P75	50 Mhz	1.5x	2-3	2-3	2-3	open	open	
P54C P90	60 Mhz	1.5x	1-2	2-3	2-3	open	open	
P54C P100	66 Mhz	1.5x	2-3	1-2	2-3	open	open	
P54C P120	60 Mhz	2.0x	1-2	2-3	2-3	close	open	
P54C P133	66 Mhz	2.0x	2-3	1-2	2-3	close	open	
P54C/P55C P150	60 Mhz	2.5x	1-2	2-3	2-3	close	close	
P54C/P55C P166	66 Mhz	2.5x	2-3	1-2	2-3	close	close	
P54C/P55C P180	60 Mhz	3x	1-2	2-3	2-3	open	close	
P54C/P55C P200	66 Mhz	3x	2-3	1-2	2-3	open	close	
P55C P233	66 Mhz	3.5x	2-3	1-2	2-3	open	open	

### New CPUs Update

If you have higher frequency CPU than above list, just follow the rules below to set your CPUs.

CPU Frequency	Bus clock	Multi-plier	JP10	JP11	JP12	JP13	JP14	JP15
266 MHz	66MHz	4.0x	2-3	1-2	2-3	short	open	short
300 MHz	66MHz	4.5x	2-3	1-2	2-3	short	short	short